

### DESCRIPTION:

The products are 2MBd high-speed opto-couplers. The device is a small-outline coupler suitable for surface-mount assembly. It consists of a high-output-power infrared LED optically coupled to a high-speed photodiode-transistor chip. It is housed in the LSOP5 and LSOP5W package and guarantees a creepage distance of  $\geq 5$  mm, a clearance of  $\geq 5$  mm and an insulation thickness of  $\geq 0.4$  mm. Therefore, it meets the reinforced insulation class requirements of international safety standards. The products are widely used in programmable controllers, industrial inverters and switching power supplies.

### MAIN FEATURES

- High isolation 5000 VRMS
- High speed – 2MBd typical
- Operating temperature range  $-40^{\circ}\text{C}$  to  $110^{\circ}\text{C}$
- REACH & RoHS compliance
- HBM: H3A; MM: M4; CDM: C3
- CQC approved
- VDE approved
- UL approved



### Truth Table

LED	Output
ON	L
OFF	H

### ABSOLUTE MAXIMUM RATINGS (Temperature= $25^{\circ}\text{C}$ )

Parameter		Symbol	Value	Unit
Input	Forward Current	$I_F$	50	mA
	Peak Forward Current	$I_{FP}$	$1^{\text{①}}$	A
	Reverse Voltage	$V_R$	6	V
	Input Power Dissipation	$P_D$	100	mW
Output	Supply Voltage	$V_{CC}$	35	V

	Output Voltage	$V_o$	20	V
	Output Current	$I_o$	8	mA
	Output Power Dissipation	$P_o$	100	mW
Total Power Dissipation		$P_{tot}$	200	mW
Isolation Voltage		$V_{iso}$	5000 <sup>②</sup>	Vrms
Operating Temperature		$T_{opr}$	-40~110	°C
Junction Temperature		$T_j$	125	°C
Storage Temperature		$T_{stg}$	-55~125	°C
Soldering Temperature		$T_{sol}$	260	°C

**NOTE1**: 100μs pulse, 100Hz frequency

**NOTE2**: AC for 1minute, R.H.=40~60%

**ELECTRICAL CHARACTERISTICS** (Temperature=25°C)

Parameter		Symbol	Condition	Min.	Typ.	Max.	Unit
Input	Forward Voltage	$V_F$	$I_F=10mA$	-	1.35	1.6	V
	Reverse Current	$I_R$	$V_R=6V$	-	-	1	μA
	Input Capacitance	$C_{in}$	$V=0, f=1MHz$	-	60	-	pF
Output	High Level Output Current	$I_{OH}$	$I_F=0mA, V_{CC}=5.5V, V_O=5.5V$	-	3	500	nA
			$I_F=0mA, V_{CC}=15V, V_O=15V$	-	-	50	μA
	Low Level Supply Current	$I_{CCL}$	$I_F=10mA$	-	-	1.3	mA
	High Level Supply Current	$I_{CCH}$	$I_F=0mA$	-	-	1.3	mA
	Logic Low Output Voltage	$V_{OL}$	$I_F=16mA, I_o=2.4mA, V_{CC}=4.5V$	-	-	0.4	V
	Isolation Resistance	$R_{iso}$	DC500V 40~60%R.H.	$10^{12}$	$10^{14}$	-	Ω
	Floating Capacitance	$C_{io}$	$V=0, f=1MHz$	-	0.8	-	pF
	Switching Characteristics	LED Trigger Current	$I_{FT}$	$I_o=0.75mA, V_o<0.8V$	-	-	5

	Propagation Delay Time to Logic Low	TPHL	$I_F=0 \rightarrow 10\text{mA}$ , $R_L=20\text{k}\Omega$ , $C_L=100\text{pF}$	30	150	400	ns
			$I_F=0 \rightarrow 10\text{mA}$ , $R_L=20\text{k}\Omega$ , $C_L=10\text{pF}$	-	70	-	ns
	Propagation Delay Time to Logic High	TPLH	$I_F=10 \rightarrow 0\text{mA}$ , $R_L=20\text{k}\Omega$ , $C_L=100\text{pF}$	150	350	550	ns
			$I_F=10 \rightarrow 0\text{mA}$ , $R_L=20\text{k}\Omega$ , $C_L=10\text{pF}$	-	110	-	ns
	Common Mode Transient Immunity at Logic High	CM <sub>H</sub>	$I_F=0\text{mA}$ , $V_{CM}=1500\text{Vpp}$ , $R_L=20\text{k}\Omega$	$\pm 20$	$\pm 25$	-	kV/ $\mu\text{s}$
	Common Mode Transient Immunity at Logic Low	CM <sub>L</sub>	$I_F=10\text{mA}$ , $V_{CM}=1500\text{Vpp}$ , $R_L=20\text{k}\Omega$	$\pm 20$	$\pm 25$	-	kV/ $\mu\text{s}$

ORDERING INFORMATION

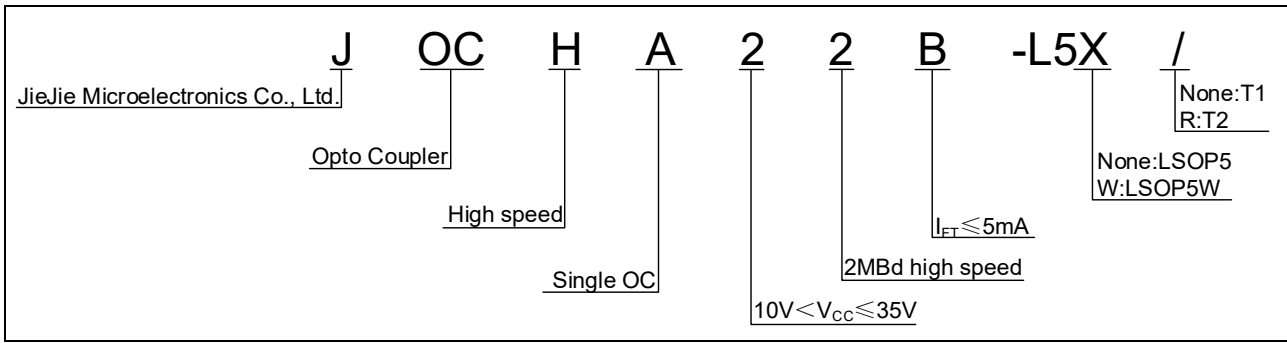

Packing Quantity			
Option	Quantity	Quantity – Inner box	Quantity –Outer box
LSOP5	3000 Units/Reel	2 Reels/Inner box	5 Inner box/Outer box =30k Units

MARKING

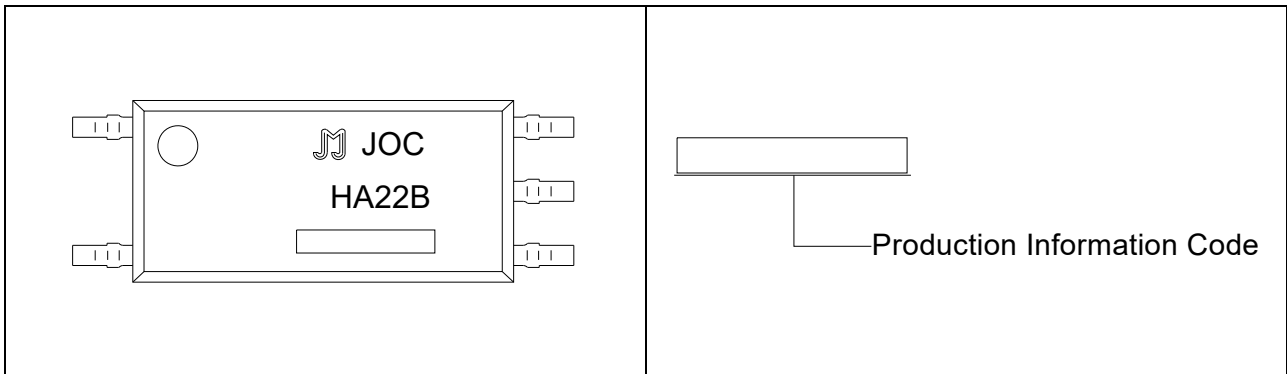

Characteristics Curves

FIG.1: Forward Current vs. Forward Voltage

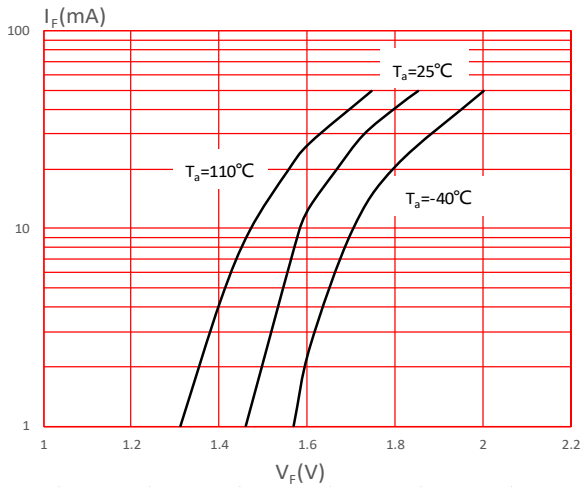

FIG.2: High Level Output Current vs. Ambient Temperature

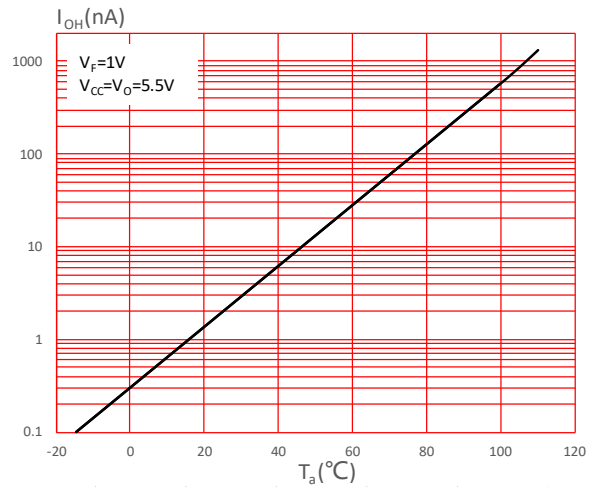

FIG.3: Output Current vs. Forward Current

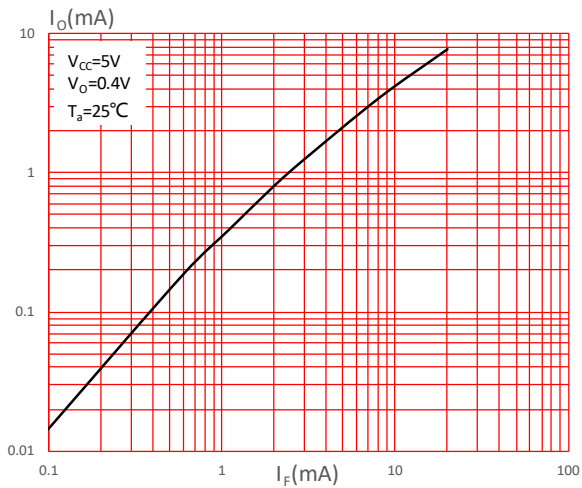

FIG.4: Threshold Input Current vs. Ambient Temperature

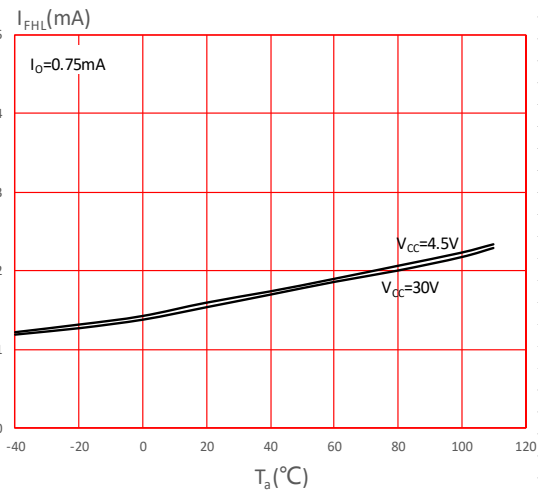

FIG.5: Output Current vs. Output Voltage

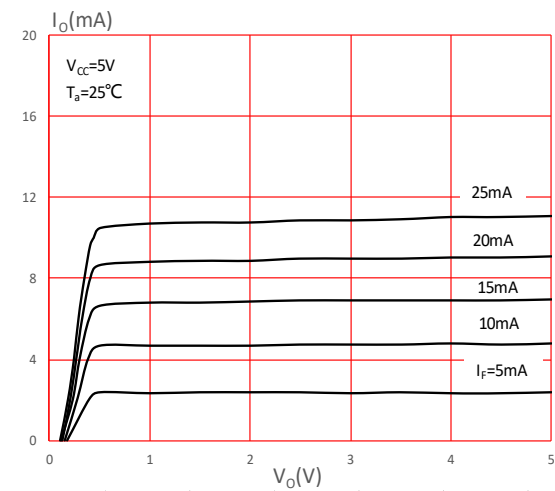

FIG.6: Low Level Output Voltage vs. Ambient Temperature

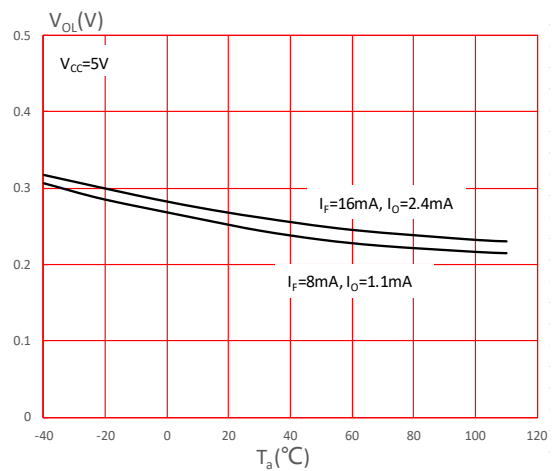

FIG.7: Propagation Delay vs. Load Resistance

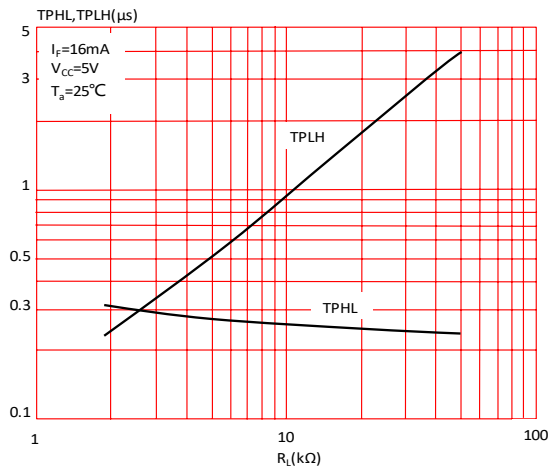
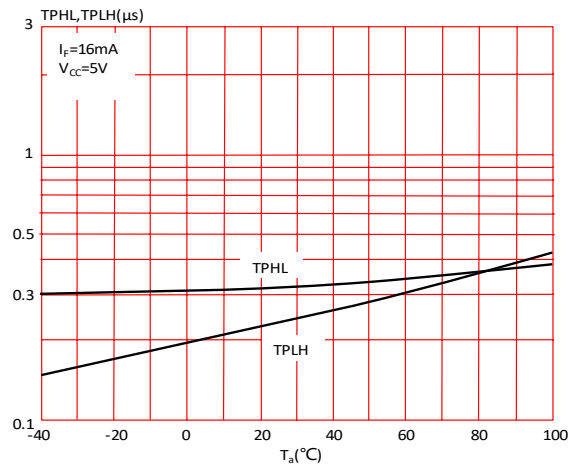

FIG.8: Propagation Delay vs. Ambient Temperature



TEST CIRCUITS

Fig.9: Switching Time Test Circuit and Waveform

$I_f = 10\text{mA (P.G.)}$   
 ( $f = 10\text{kHz}$ , duty=10%,  $t_r = t_f = 5\text{ns}$  or less)

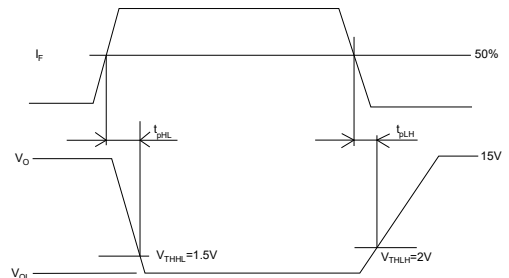
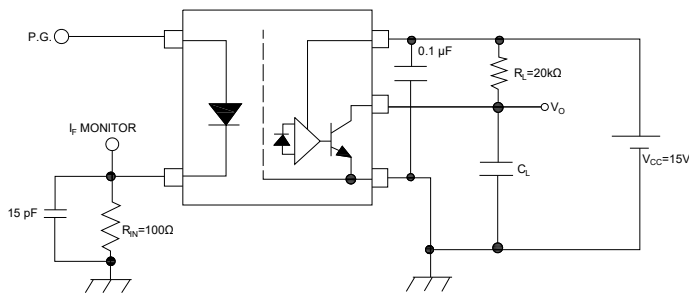
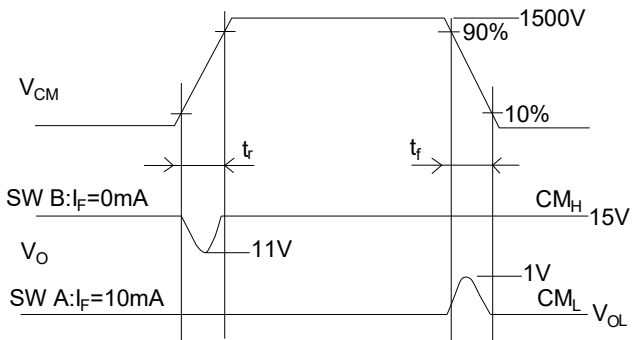
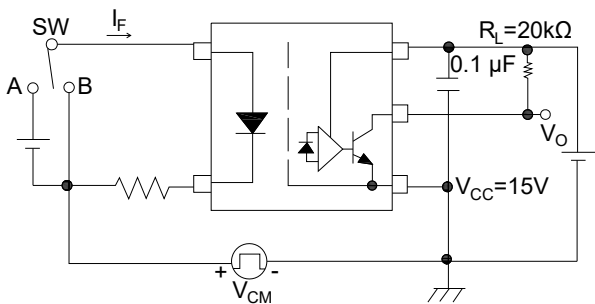
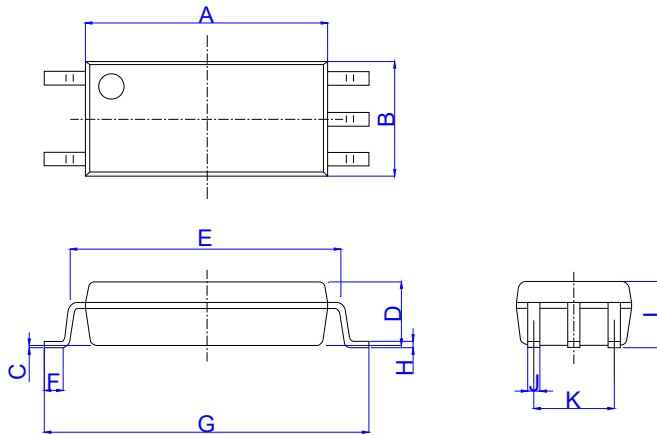

Fig.10: CMTI Test Circuit and Waveform



Package Dimension (Unit: mm)

LSOP5



Ref.	Dimensions					
	Millimeters			Inches		
	Min.	Typ.	Max.	Min.	Typ.	Max.
A	7.40		7.80	0.291		0.307
B	3.40		3.80	0.134		0.150
C	0.00		0.20	0.000		0.008
D	1.80		2.20	0.071		0.087
E	8.10		8.70	0.319		0.343
F	0.40		1.00	0.016		0.039
G	9.90		10.50	0.390		0.413
H	0.10		0.30	0.004		0.012
I	1.80		2.40	0.071		0.094
J	0.25		0.55	0.010		0.022
K	2.29		2.79	0.090		0.110

LSOP5W

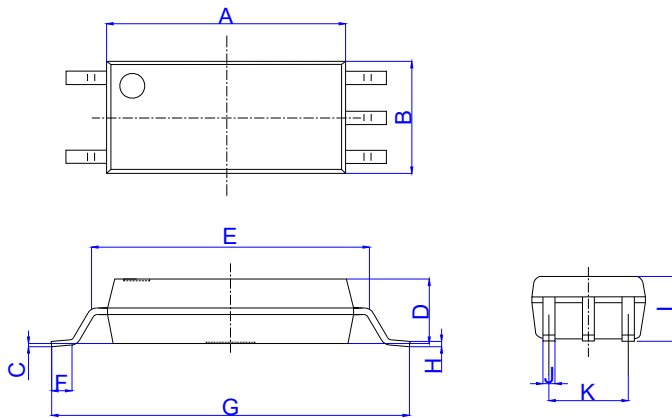

Ref.	Dimensions					
	Millimeters			Inches		
	Min.	Typ.	Max.	Min.	Typ.	Max.
A	7.40		7.80	0.291		0.307
B	3.40		3.80	0.134		0.150
C	0.00		0.20	0.000		0.008
D	1.80		2.20	0.071		0.087
E	8.10		8.70	0.319		0.343
F	0.55		1.15	0.022		0.045
G	10.78		11.38	0.424		0.448
H	0.06		0.26	0.002		0.010
I	1.80		2.40	0.071		0.094
J	0.25		0.55	0.010		0.022
K	2.29		2.79	0.090		0.110

RECOMMENDED SOLDER MASK (Dimensions in mm unless otherwise stated)

LSOP5

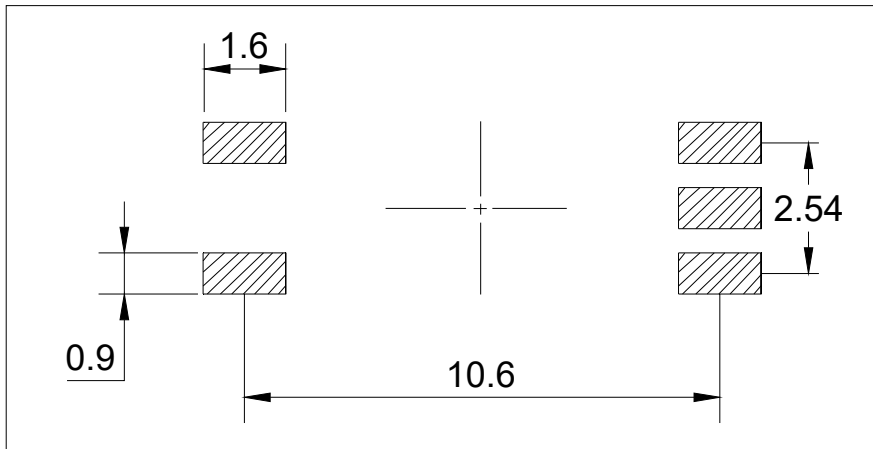

LSOP5W

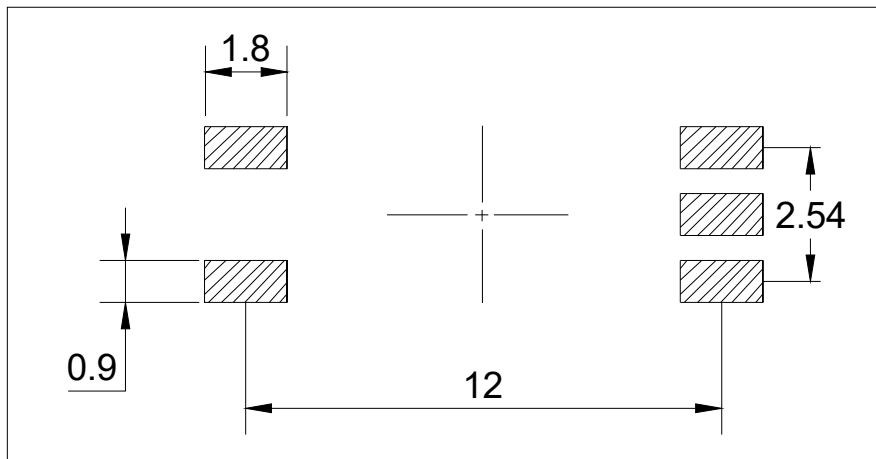

CARRIER TAPE SPECIFICATIONS (Dimensions in mm unless otherwise stated)

Option None/R

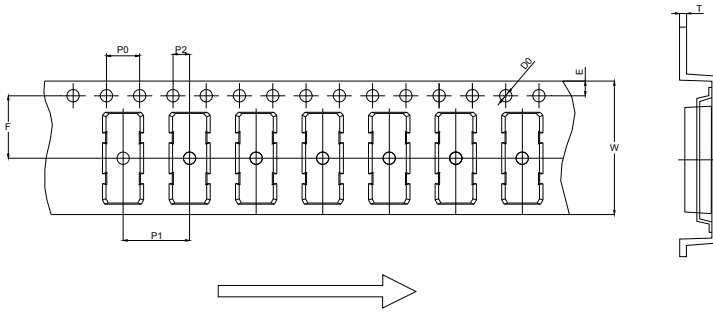

Ref.	Dimensions					
	Millimeters			Inches		
	Min.	Typ.	Max.	Min.	Typ.	Max.
D0	1.50	1.55	1.60	0.059	0.061	0.063
P0	3.90	4.00	4.10	0.154	0.157	0.161
P1	7.90	8.00	8.10	0.311	0.315	0.319
P2	1.90	2.00	2.10	0.075	0.079	0.083
E	1.65	1.75	1.85	0.065	0.069	0.073
F	7.40	7.50	7.60	0.291	0.295	0.299
T	0.35	0.40	0.45	0.014	0.016	0.018
W	15.80	16.00	16.20	0.622	0.630	0.638

REFLOW INFORMATION

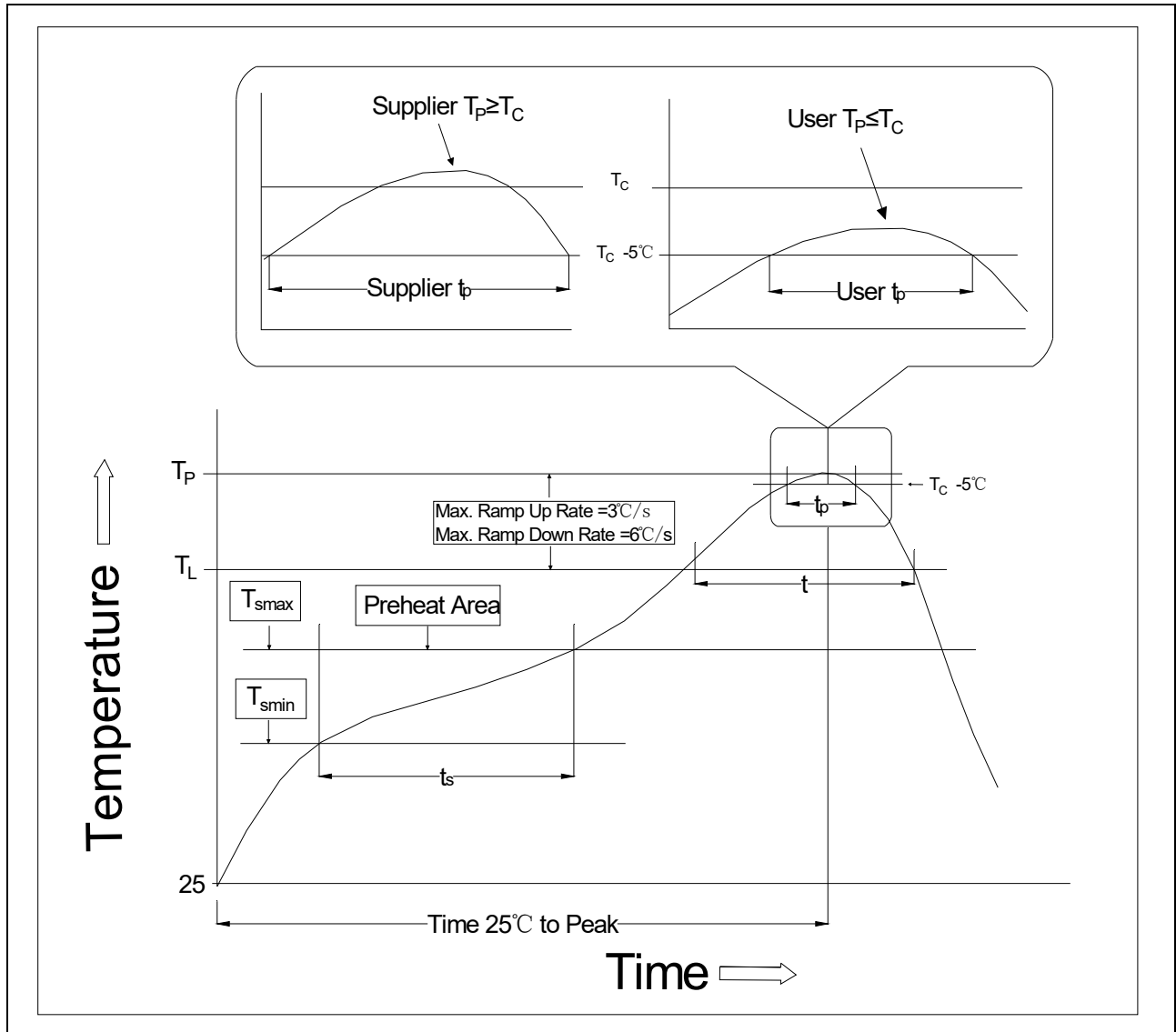

Profile Feature	Sn-Pb Assembly Profile	Pb-Free Assembly Profile
Temperature Min. (T <sub>smin</sub> )	100°C	150°C
Temperature Max. (T <sub>smax</sub> )	150°C	200°C
Time (t <sub>s</sub> ) from (T <sub>smin</sub> to T <sub>smax</sub> )	60-120 seconds	60-120 seconds
Ramp-up Rate (t <sub>L</sub> to t <sub>P</sub> )	3°C/second max.	3°C/second max.
Liquidus Temperature (T <sub>L</sub> )	183°C	217°C
Time (t <sub>L</sub> ) Maintained Above (T <sub>L</sub> )	60-150 seconds	60-150 seconds
Peak Body Package Temperature	235°C+0°C/-5°C	260°C+0°C/-5°C
Time (t <sub>P</sub> ) within 5°C of 260°C	10 seconds	10 seconds
Ramp-down Rate (T <sub>P</sub> to T <sub>L</sub> )	3-6°C/second	3-6°C/second
Time 25°C to Peak Temperature	6 minutes max.	8 minutes max.

Note:

1. Reflow soldering is recommended at the temperatures and times shown, no more than three times.
2. Avoid direct contact between the epoxy body and any tools or surfaces exceeding its maximum storage temperature.
3. Application of pressure on the epoxy body is prohibited at elevated temperatures. In specific scenarios, any applied force must not exceed 2.5N.
4. Ensure the component has cooled to ambient temperature before proceeding with any subsequent manufacturing steps.
5. The component has a shelf life of one year when stored under standard conditions.
6. Recommend storage Temp.: 0~40°C;  
Recommend storage humidity: <60%;  
MSL level: MSL 1

Information furnished in this document is believed to be accurate and reliable. However, Jiangsu JieJie Microelectronics Co., Ltd. assumes no responsibility for the consequences of use without consideration for such information nor use beyond it. Information mentioned in this document is subject to change without notice, apart from that when an agreement is signed, Jiangsu JieJie complies with the agreement.

Products and information provided in this document have no infringement of patents. Jiangsu JieJie assumes no responsibility for any infringement of other rights of third parties which may result from the use of such products and information. This document supersedes and replaces all information previously supplied.

 is a registered trademark of Jiangsu JieJie Microelectronics Co., Ltd.

Copyright © 2026 Jiangsu JieJie Microelectronics Co., Ltd. All rights reserved.